

RADIANCE

10MBPS REDUNDANT INTERFACE LINE CARD

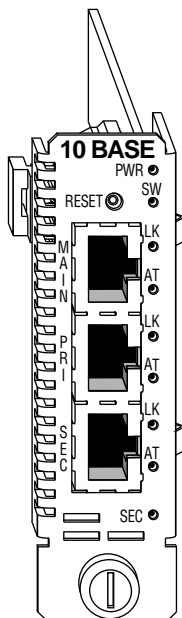

Installation & User Guide

Model: R711-11

Radiance 10Mbps Redundant Interface Line Card

R711-11 _____ RJ-45 to redundant RJ-45

This publication is protected by the copyright laws of the United States and other countries, with all rights reserved. No part of this publication may be reproduced, stored in a retrieval system, translated, transcribed, or transmitted, in any form, or by any means manual, electric, electronic, electromagnetic, mechanical, chemical, optical or otherwise, without prior explicit written permission of Metrobility Optical Systems, Inc.

Table of Contents

Radiance 10Mbps Redundant Interface Line Card Installation & User Guide

Overview	4
Installation Guide	6
Unpack the Line Card	6
Set the DIP Switches	6
Set the MDI-II/MDI-X Switch	9
Install the Line Card	10
Connect to the Network	11
User Guide	13
LED Operation	13
Reset Push Button	14
Link Loss Carry Forward (LLCF)	15
Topology Solution	16
Technical Specifications	17
Product Safety, EMC and Compliance Statements	18
Warranty and Servicing	19

Metrobility, Metrobility Optical Systems, and NetBeacon are registered trademarks of Metrobility Optical Systems, Inc. The Metrobility Optical Systems logo is a trademark of Metrobility Optical Systems, Inc. Other trademarks appearing in this manual are the property of their owners.

“redundant twister” technology is a patent of Metrobility Optical Systems, Inc.

The information contained in this document is assumed to be correct and current. The manufacturer is not responsible for errors or omissions and reserves the right to change specifications at any time without notice.

Overview

The Radiance 10Mbps redundant interface line card offers the resiliency of data link redundancy to ensure network integrity with no down time. This link duplication provides the nonstop networking capability essential for high priority traffic and mission-critical applications. The Radiance 10Mbps redundant interface line card provides full redundant data paths for Ethernet devices. The card actively monitors the primary link and, if it fails, automatically activates the secondary link without interruption to network operation.

Management control over the Radiance redundant interface line card allows the network administrator to monitor and configure the card via a PC using console commands, our NetBeacon® or WebBeacon management software, or any SNMP application.

The Radiance 10Mbps redundant interface line card contains a MAIN port, a PRIMARY port and a SECONDARY port. Redundancy is provided between the PRIMARY and SECONDARY ports.

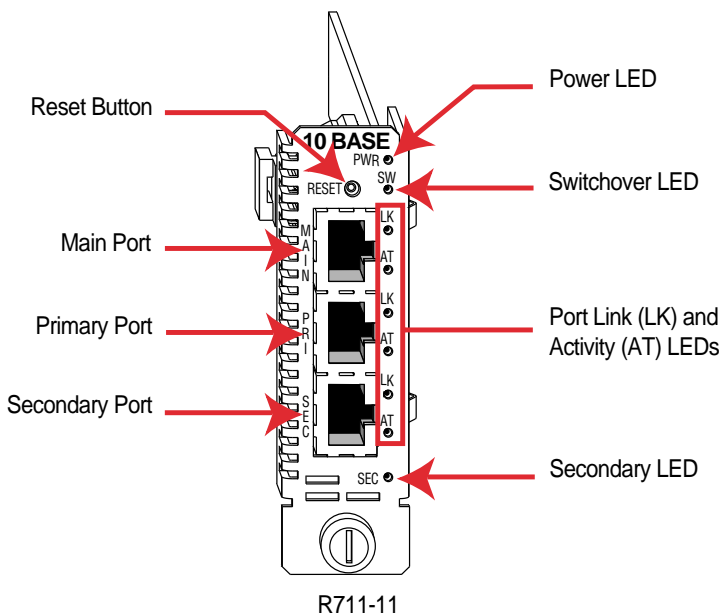

The Radiance 10Mbps redundant interface card provides the following features:

- Dynamic Recovery Mode (DRM) operation to ensure session integrity and increased uptime.
- Network Select Mode (NSM) operation to redirect and isolate traffic adding extra security.
- Immediate switching from the primary link to the secondary link if the primary link fails.
- Minimal impact on the round trip delay for communication in half-duplex collision domains.
- Twisted-pair ports equipped with MDI-II to MDI-X switches to eliminate the need for crossover cables.
- Can be configured to return automatically to the primary link after the failure condition is resolved or only upon secondary failure, or manually switched back to primary after failover.
- Full- and half-duplex support.
- Auto-polarity support on all twisted-pair ports.
- In addition to providing link and data on the active ports, the Radiance redundant interface line card can be configured to provide link or link-and-redundant-transmit-data on the inactive port.
- Link Loss Carry Forward* enable/disable switch.
- Compatibility with devices configured for auto-negotiation.
- Fast failover time (400 ms) ensures low packet loss.
- Fused power on the card to protect the system from a short circuit. This prevents a faulty card from bringing down an entire system.
- Full compliance with applicable sections of IEEE 802.3/802.3u.
- Transparent to data frame sizes.

* Refer to the page titled [Link Loss Carry Forward \(LLCF\)](#) in the User Guide section of this document for additional information.

Installation Guide

Follow the simple steps outlined in this section of the manual to install and start using your Radiance 10Mbps redundant interface line card.

NOTE: Electrostatic discharge precautions should be taken when handling any line card. Proper grounding is recommended (i.e., wear a wrist strap).

1 **Unpack the Line Card**

Your order has been provided with the safest possible packaging, but shipping damage does occasionally occur. Inspect your order carefully for damage that may have occurred during shipment. If you discover any shipping damage, notify the carrier and follow their instructions for damage and claims. Save the original shipping carton if return or storage of the unit is necessary.

2 **Set the DIP Switches**

A set of DIP switches, located on the line card, provides user-selectable configuration options for several modes of operation. These switches are clearly marked on the printed circuit board. Refer to the table on the following pages for the proper setting of the DIP switches.*

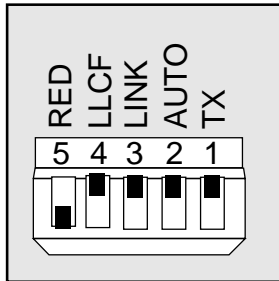

R711-11

* DIP switches can also be managed via console commands or through Metrobility's NetBeacon or WebBeacon management software. Refer to the **Radiance Command Line Interface Reference Guide**, **NetBeacon Element Management Software Installation & User Guide** or **WebBeacon Management Software Installation & User Guide** for software management information.

The DIP switches for the R711-11 can be set for the following operational functions:

Switch Name	Position*	Operation
TX	UP	Transmits data on both the PRIMARY and SECONDARY ports simultaneously. The LINK switch must be enabled on both ports.
	DOWN <i>(default)</i>	Transmits data on the active port only.
AUTO	UP	Automatically reverts the active port back to the PRIMARY port when the primary link is reestablished.
	DOWN <i>(default)</i>	Does not revert the active port back to the PRIMARY port when the primary link is reestablished until the SECONDARY link fails. If the SECONDARY link does not fail, the SECONDARY port remains active. Use the RESET push button located on the front of the card to force the active port back to the PRIMARY port and to clear the switchover (SW) LED.
LINK	UP	Link signals are sent out on both the PRIMARY and SECONDARY ports (i.e., link is sent out both ports).
	DOWN <i>(default)</i>	Link signals are sent out on the active port only. With the LINK switch in this position, data is <u>not</u> transmitted out the inactive port regardless of the TX switch setting.
LLCF	UP	Link Loss Carry Forward is enabled.
	DOWN <i>(default)</i>	Link Loss Carry Forward is disabled.

* When setting DIP switches, the UP position is when the lever of the switch is pushed away from the circuit board. The DOWN position is when the lever of the switch is pushed toward the board.

Switch Name	Position	Operation
RED	UP <i>(default)</i>	Operates in Dynamic Recovery Mode (DRM). If the primary link fails, the SECONDARY port becomes active. Refer to the description for the AUTO switch.
	DOWN	Operates in Network Select Mode (NSM). Use the RESET push button to toggle between PRIMARY and SECONDARY. In NSM, the AUTO switch sets the initial active port on power-up. Note that the SW LED remains off in NSM.

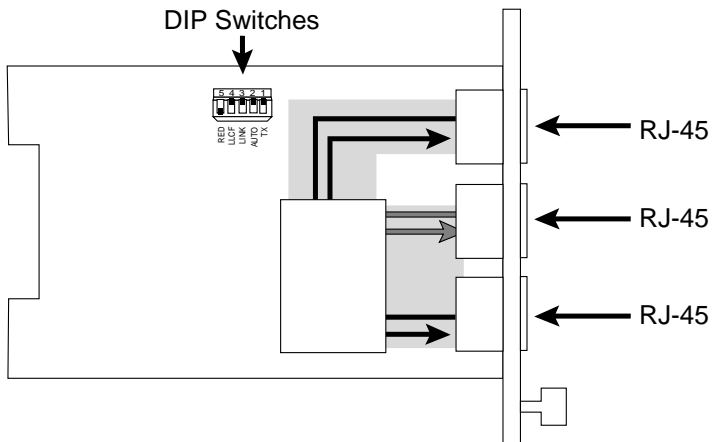

3

Set the MDI-II/MDI-X Switch

For each twisted-pair port, a switch is used to implement the transmit and receive crossover functionality. The switch is positioned just behind its associated RJ-45 connector. See the illustration below for the location of the MDI-II/MDI-X slide switches.

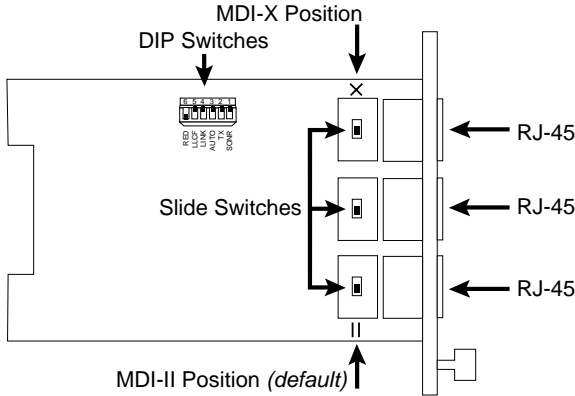

The switch connects the transmit and receive signal pairs in either straight-through or crossover configurations. The signal routing is as follows:

Switch Position	Connection
	TX+ to TX+ TX- to TX- RX+ to RX+ RX- to RX-
X	TX+ to RX+ TX- to RX- RX+ to TX+ RX- to TX-

When setting the MDI-II/MDI-X switch, observe the positioning of the following symbols:

- the parallel symbol (||) indicates a straight-through or parallel connection (*default*)
- the cross symbol (X) indicates a crossover connection.

These two symbols are clearly marked on the printed circuit board. Simply slide the switch in the direction of the appropriate symbol.

4 **Install the Line Card**

The Radiance 10Mbps redundant interface line card offers the ease of plug-and-play installation and is hot-swappable. All cards must be firmly secured to the chassis before network connections are made. Follow the simple steps outlined below to install the line card.

NOTE: Proper grounding is recommended (i.e., wrist strap).

- Grasp the card by the front panel as shown.

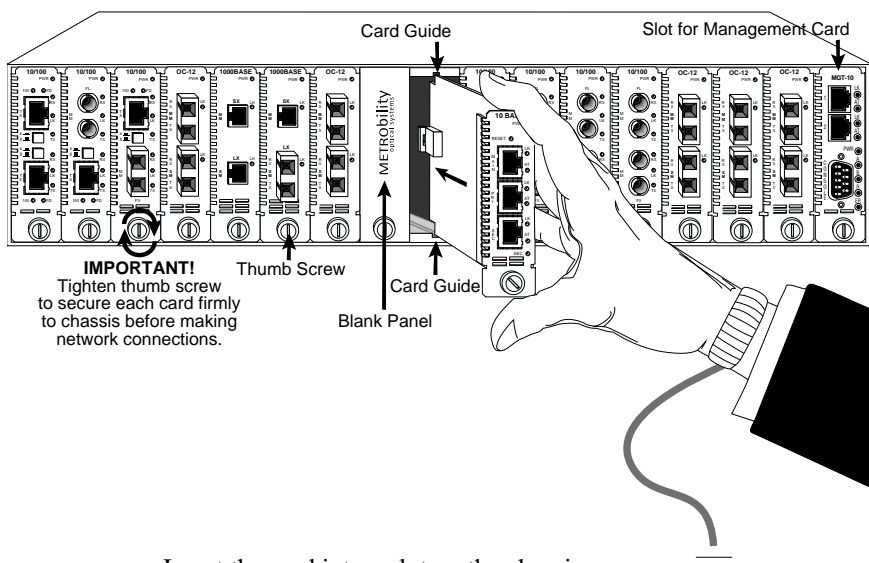

- Insert the card into a slot on the chassis making sure that the top and bottom edges of the card are aligned with the top and bottom card guides in the chassis. Do not force the card into the chassis unnecessarily. It should slide in easily and evenly.
- Slide the card in until the top and bottom edges of the front panel are flush and even with the top and bottom edges of the chassis.
- Turn the thumbscrew clockwise until it is snug to secure the card to the chassis. The card is now properly installed and ready for connection to the network.

5

Connect to the Network

A total of three connections must be made on the front panel when connecting the line card to the network. Make sure that all cards are firmly secured to the chassis before making network connections.

- Connect to the MAIN port.
The Radiance redundant interface line card provides one shielded RJ-45 jack for 10BASE-T connections and supports a maximum segment length of 100 meters over Category 3, 4 or 5 twisted-pair cable.

Refer to [STEP 3](#) for MDI-II to MDI-X switch functionality. Before making the proper twisted-pair connection, verify the port configuration of the connected device.

If you do not know the internal wiring configuration of the other device's RJ-45 port, consult the product documentation.

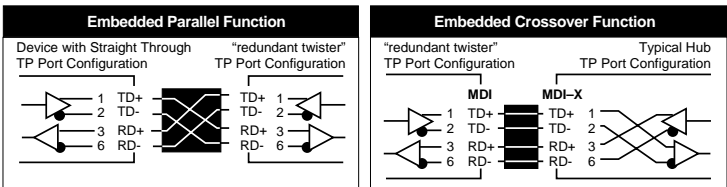

A device that is wired straight through, needs one crossover connection:	
If the cable is...	... the MDI-II to MDI-X Switch Setting should be
straight through	X
crossover	II

A device that is wired crossover, needs a parallel connection:	
If the cable is...	... the MDI-II to MDI-X Switch Setting should be
straight through	II
crossover	X

- Connect to the PRIMARY port.
- Connect to the SECONDARY port.
The R711-11 provides two additional RJ-45 jacks for 10BASE-T connections and support a maximum segment length of 100 meters over Category 3, 4 or 5 twisted-pair cable.

Use the link (LK) LEDs on the front panel of the card to verify correct segment connectivity. As you insert the cable into each port, the LK LED illuminates provided there is power being applied to the chassis and there is an active device connected to the other end of the cable sending idle link signals.

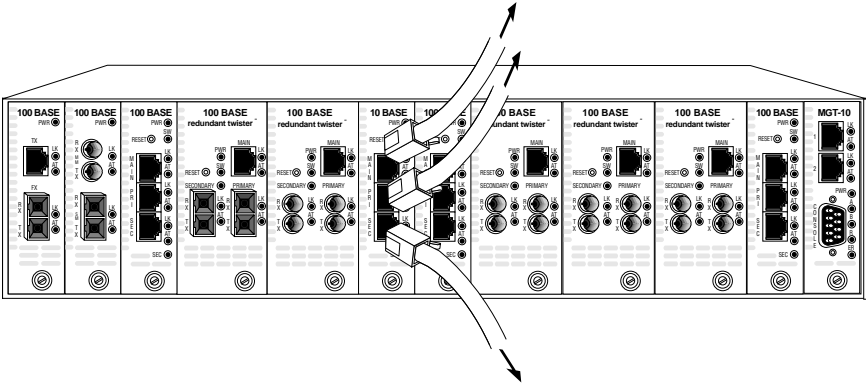

User Guide

This section contains information regarding the operating features of your Radiance 10Mbps redundant interface line card.

LED Operation

Several LEDs are visible from the front panel. These include the switchover (SW), power (PWR), secondary (SEC), link (LK) and activity (AT) LEDs. There are separate link and activity LEDs for each of the three ports (MAIN, PRIMARY and SECONDARY). Refer to the table below for a description of each.

The indication of each LED is as follows:

LED Label	Color (Status)	Indication
SW	Amber (steady)	SECONDARY port was the active port at some point. This LED functions in Dynamic Recovery Mode (DRM) only.
PWR	Green (steady)	Power ON
SEC	Green (steady)	SECONDARY port is active
	OFF	PRIMARY port is active
(MAIN) LK	Green (steady)	Receive link present
(MAIN) AT	Green (blinking)	Receiving data
(PRIMARY) LK	Green (steady)	Receive link present
(PRIMARY) AT	Green (blinking)	Receiving data
(SECONDARY) LK	Green (steady)	Receive link present
(SECONDARY) AT	Green (blinking)	Receiving data

Reset Push Button

A small RESET push button is located on the front panel of the Radiance redundant interface line card. When used in conjunction with the card's SW and SECONDARY LEDs and the AUTO DIP switch setting, this push button allows you to effectively maintain or troubleshoot a PRIMARY link connection.

Because of its small size and recessed placement within the front panel, press the RESET push button with the tip of a pointed object. Pushing and holding the RESET push button has no effect. It is the act of pressing the push button that causes a reset.

In the event of a PRIMARY link failure, pressing the RESET push button has the following effects:

If the AUTO switch is UP and RED switch is UP	The active port automatically reverts to PRIMARY when primary link is reestablished and pressing the RESET switch clears the SW LED.
If the AUTO switch is DOWN and the RED switch is UP	The active port does <u>not</u> automatically revert to PRIMARY when a primary link is reestablished. Pressing the RESET switch clears the SW LED and the SECONDARY LED and forces the PRIMARY port to be the active port. If the SECONDARY link is disabled, it reverts to the PRIMARY if the PRIMARY has a good link.
	If there is only a SECONDARY link, then the SW and SECONDARY LEDs remain lit and pressing the RESET switch has no effect.
If the RED switch is DOWN	The card operates in Network Select Mode (NSM). The RESET push button toggles the active link between the PRIMARY and SECONDARY ports. Note that the SW LED remains off during Network Select Mode (NSM) operation.

Link Loss Carry Forward (LLCF)

The Radiance 10Mbps redundant interface line card has been designed with Link Loss Carry Forward ability for troubleshooting a remote connection. The card is shipped with LLCF disabled.

When LLCF is enabled, the ports on the card do not transmit a link signal until they receive a link signal from the opposite port. For example, if LLCF is enabled and two redundant interface line cards are connected with nothing else connected to them, the Link LED is *not* lit. When a valid link is established, a complete connection is accomplished.

The diagram below shows a typical network configuration using Radiance redundant interface line cards for remote connectivity:

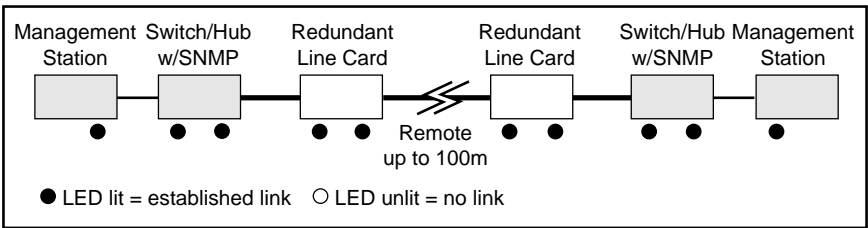

If the connection breaks, or the remote device fails, the card carries that link loss all the way to the switch/hub which generates a trap to the management station. The administrator can then look at the card to determine the source of the loss.

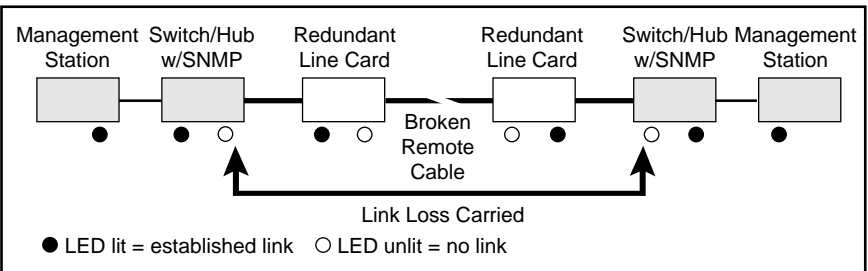

Topology Solution

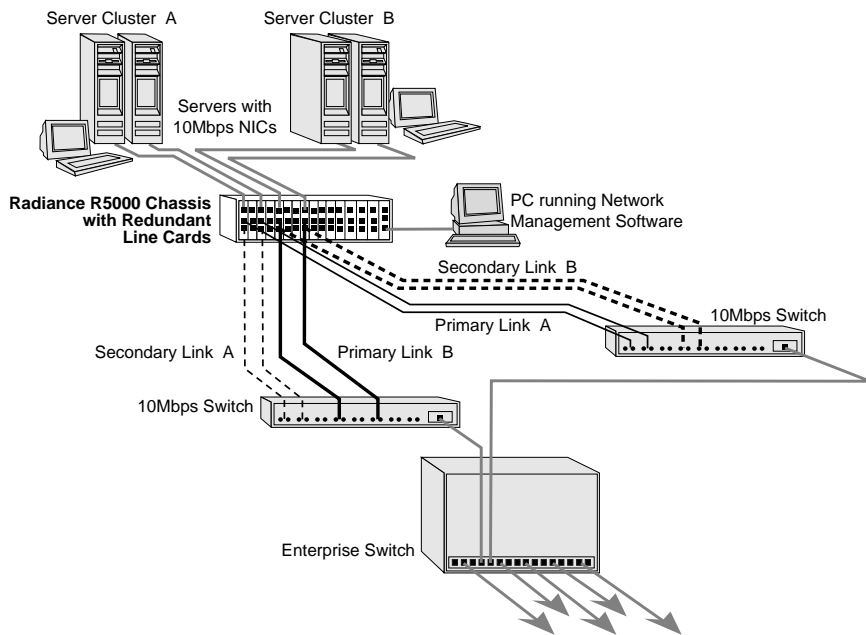

Technical Specifications

Data Rate

Half duplex _____ 10Mbps
Full duplex _____ 20Mbps

10Mbps Twisted-Pair Interface

Connector _____ Shielded RJ-45, 8-pin jack
Impedance _____ 100 Ohms nominal
Signal Level Output (differential) _____ 2.2 to 2.8V
Signal Level Input _____ .3 to 3.1V p-p
Supported Link Length _____ 100m
Cable Type _____ Category 3, 4, or 5 UTP
(For NEBS Level III and EN55024:1998 compliance, use only
Category 5 STP cables.)

Power Requirements

Input _____ 5V DC @ 0.750A, 3.75W

Environmental

Operating Temperature _____ 0 to 50° C
Storage Temperature _____ -30 to 70° C
Operating Humidity _____ 5% to 95% non-condensing
Weight _____ 5 oz (0.14 kg)

Product Safety, EMC and Compliance Statements

This equipment complies with the following requirements:

- UL
- CSA
- EN60950 (safety)
- FCC Part 15, Class A
- EN55022 Class A (emissions)
- EN55024: 1998 (immunity)
- DOC Class A (emissions)
- IEC 825-1 Classification
- Class 1 Laser Product

This product shall be handled, stored and disposed of in accordance with all governing and applicable safety and environmental regulatory agency requirements.

The following *FCC* and *Industry Canada* compliance information is applicable to North American customers only.

USA FCC Radio Frequency Interference Statement

This equipment has been tested and found to comply with the limits for a Class A digital device, pursuant to Part 15 of the FCC Rules. These limits are designed to provide reasonable protection against harmful interference when the equipment is operated in a commercial environment. This equipment generates, uses and can radiate radio frequency energy, and if not installed and used in accordance with the instruction manual, may cause harmful interference to radio communications. Operation of this equipment in a residential area is likely to cause harmful interference in which case the user will be required to correct the interference at his own expense.

***Caution:** Changes or modifications to this equipment not expressly approved by the party responsible for compliance could void the user's authority to operate the equipment.*

Canadian Radio Frequency Interference Statement

This Class A digital apparatus meets all requirements of the Canadian Interference-Causing Equipment Regulations.

Cet appareil numérique de la classe A respecte toutes les exigences du Règlement sur le matériel brouilleur du Canada.

Warranty and Servicing

Three-Year Warranty for Radiance 10Mbps Redundant Interface Line Card

Metrobility Optical Systems, Inc. warrants that every Radiance 10Mbps redundant interface line card will be free from defects in material and workmanship for a period of THREE YEARS from the date of Metrobility shipment. This warranty covers the original user only and is not transferable. Should the unit fail at any time during this warranty period, Metrobility will, at its sole discretion, replace, repair, or refund the purchase price of the product. This warranty is limited to defects in workmanship and materials and does not cover damage from accident, acts of God, neglect, contamination, misuse or abnormal conditions of operation or handling, including overvoltage failures caused by use outside of the product's specified rating, or normal wear and tear of mechanical components.

To establish original ownership and provide date of purchase, complete and return the registration card or register the product online at www.metrobility.com. If product was not purchased directly from Metrobility, please provide source, invoice number and date of purchase.

To return a defective product for warranty coverage, contact Metrobility Customer Service for a return materials authorization (RMA) number. Send the defective product postage and insurance prepaid to the address provided to you by the Metrobility Technical Support Representative. Failure to properly protect the product during shipping may void this warranty. The Metrobility RMA number must be clearly on the outside of the carton to ensure its acceptance.

Metrobility will pay return transportation for product repaired or replaced in-warranty. Before making any repair not covered by the warranty, Metrobility will estimate cost and obtain authorization, then invoice for repair and return transportation. Metrobility reserves the right to charge for all testing and shipping costs incurred, if test results determine that the unit is without defect.

This warranty constitutes the buyer's sole remedy. No other warranties, such as fitness for a particular purpose, are expressed or implied. Under no circumstances will Metrobility be liable for any damages incurred by the use of this product including, but not limited to, lost profits, lost savings, and incidental or consequential damages arising from the use of, or inability to use, this product. Authorized resellers are not authorized to extend any other warranty on Metrobility's behalf.

Product Manuals

The most recent version of this manual is available online at
<http://www.metrobility.com/support/manuals.htm>

Product Registration

To register your product, go to
<http://www.metrobility.com/support/registration.asp>

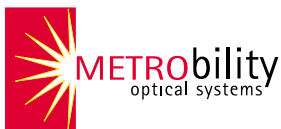

25 Manchester Street, Merrimack, NH 03054 USA
tel: 1.603.880.1833 • fax: 1.603.594.2887
www.metrobility.com